

Buck-boost transformer and PWM topology help OEMs operate equipment in countries with mains fluctuating outside design limits

Background

Automatic voltage regulators (AVR) are used in countries with insufficient infrastructure for the generation, transmission, and distribution of electricity; in industrialized countries where grids are weak, and inside facilities with inadequate electrical wiring. Conventional AVR technology has not kept pace with the requirements of the sophisticated electronics it protects. The high-speed AVR recently developed by TSI Power Corporation and Romarsh Ltd. addresses the new reality.

The electrical mains were designed to provide power to linear loads such as light bulbs and heaters. The power they draw from the mains decreases with supply voltage, mitigating some of the consequences of low supply voltage. Modern power converters used in computing, telecommunications, and industrial equipment are based on the principle of constant power. Where the current draw increases when the supply voltage decreases, thus compounding problems within the distribution systems. Problems with transmission and distribution are primarily found in developing countries, which tend to have an inadequate electrical infrastructure. The problem also exists in industrialized countries, but in a different form; namely, weak local distribution systems and/or inadequate electrical wiring in some buildings create mains voltage stability problems.

Modern electricity systems are based on high-inertia generation, stiff transmission backbone, and adequately sized distribution systems to permit very quick clearing of local faults in order to prevent interruptions upstream. Various regulatory bodies and standards organizations assume that the mains supply voltage is fairly stable since specific standards are based on conditions within EU and the USA. Constant power loads, whether linear (if power-factor corrected) or non-linear (such as power converters), therefore, are designed to perform within set limits, i.e., 184 to 264V and with permanent operation allowed between normalized 208 to 240V. The same is true for inductive loads (e.g., air conditioners and other AC motors). Manufacturers of these devices all operate in a competitive international market and thus will not over-engineer power supplies using magnetic and semi-conductor components with higher voltage ratings than actually required by the standard input voltage envelope. OEMs integrate these products into their systems so as to be subject to the same limitations. Hence the need for added mains voltage regulation when a system operates from an inadequate mains supply.

One economical way to mitigate such problems is using a modern AVR. Unfortunately, current AVR technology was developed years ago and has not kept pace with today's reality. The most prevalent technologies currently in use are of the servo and tap-switching types. It is the end user's responsibility to assess whether the mains supply is of sufficient quality to provide power to sensitive equipment. The burden of selecting a proper solution that meets technical requirements also falls on the end user, who may or may not be qualified to deal with this--sometimes a consultant is hired to provide recommendations. In order to shed some light on the relevant issues, this article will discuss the advantages and drawbacks of these established technologies while describing the newly developed, high-speed AVR.

AVR System Requirements

Regardless of technology, an AVR for today's sophisticated equipment must operate without causing disruption or additional problems to the user's connected load. Such problems may occur due to the inherent design of an AVR. The following performance characteristics are deemed essential:

- Voltage correction must begin in 20ms as power converters typically have a hold-up time of 20ms.
- Output regulation as a percentage of nominal supply voltage should be precise
- Low impedance to minimize load induced voltage swings.
- No breaking of power path during switching
- High efficiency
- Fail safe
- Automatic bypass in case of failure
- Reliability

How the Technologies Compare

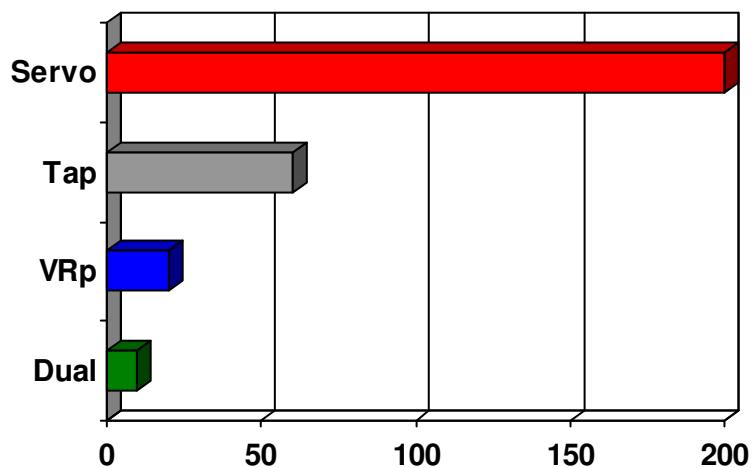

Figure 1. Response time in ms

The Electromechanical Servo AVR

An electro-mechanical regulator uses a servo motor to turn the crank of an internal variable transformer to change the input voltage to the primary of a series connected buck-boost transformer. The servo receives its control voltage from the output of a feedback and control system that monitors the output voltage of the secondary winding of the buck-boost. The supply voltage is connected to the other end of the buck-boost and load current returns via the system neutral.

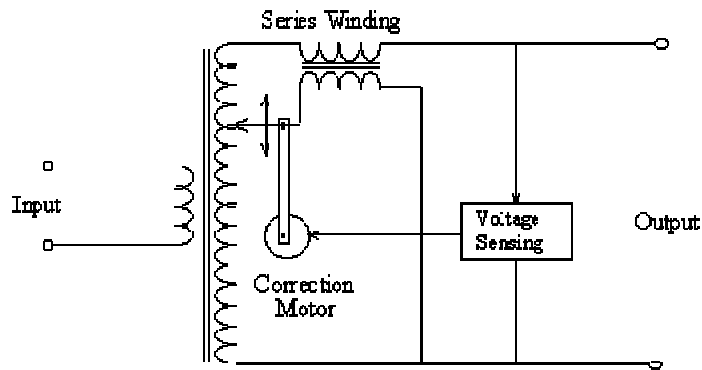

Figure 2. Electromechanical Servo AVR

The Electronic Tap-switching AVR

An electronic regulator uses either an isolation or auto transformer with regulation taps on secondary winding. The typical number of taps range from three (3) to seven (7) which translates into the same number of regulation steps—the more steps the more precise the regulated output voltage. The taps are switched either using mechanical relays or SCRs (for higher-current systems). The switches are controlled by a voltage output from a feedback and control system comparator, which compares input voltage against a reference value—the error output causes the switches to change to the appropriate tap.

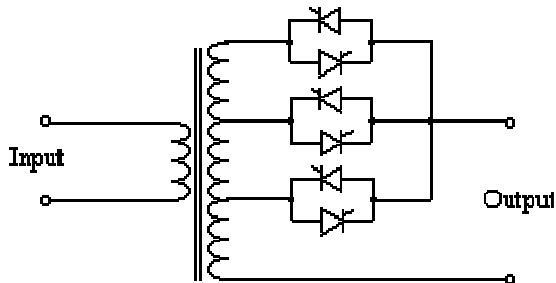

Figure 3. Electronic tap-switching AVR

Dual Conversion AVR

AC input is connected to a full-bridge rectifier that feeds a high-frequency boost converter circuit. The secondary of the boost converter forms the DC link that feeds the input of the DC-AC power inverter. The inverter output voltage and frequency can be the same as input or be set to a different voltage and frequency.

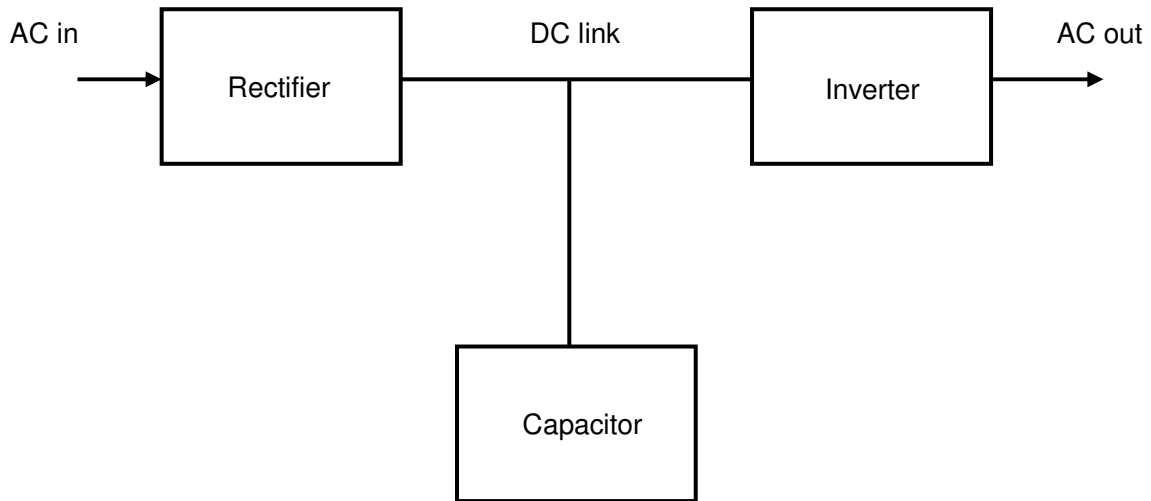

Figure 4. Dual conversion AVR

High-speed VRp PWM AVR

Its basic topology is a buck-boost transformer with a primary to secondary ratio of 5:1 for a voltage correction of $\pm 20\%$. The input phase is connected to one end of the secondary, while the critical load is connected to the other end of the secondary with the current returning to the source via the neutral wire. The control voltage is imposed on the primary winding by connecting one end of the primary to the incoming phase, while the other end of the primary is connected to the neutral—in this manner 20% of the input voltage will be added to the secondary winding. If the connections are reversed the voltage will drop 20%, as the magnetic flux imposed by the primary winding is bucking the secondary winding.

VRp System Architecture

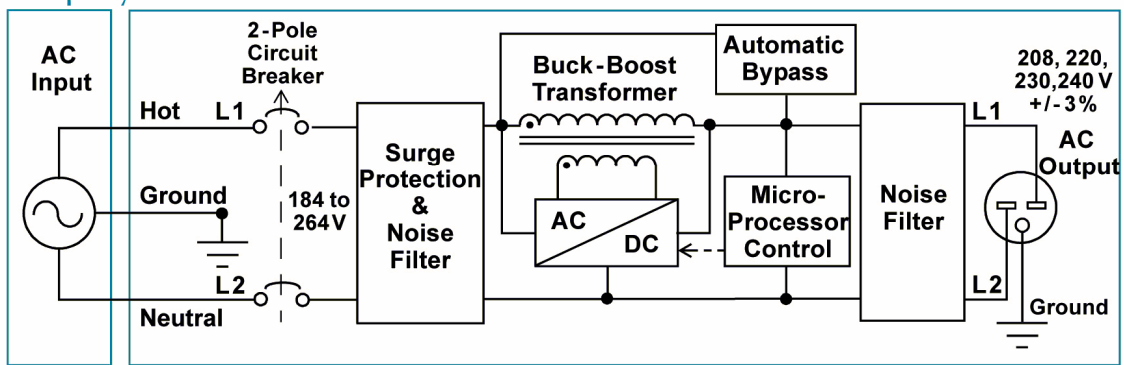

Figure 5. High-speed VRp PWM AVR

The basic idea of VRp is to accomplish this task electronically without the step changes in voltage that occur when the system regulates. This is accomplished through a feedback and control system implemented by using a microcontroller.

The system uses internal gate bipolar transistor (IGBT) power switches to form two power stacks. Rectified voltage is supplied to the inverter, the microprocessor measures the system output voltage fed back from the system and compares this voltage against a

reference. Corrections are made by varying the duty cycle of PWM pulses. The more voltage that needs to be added the longer the duty cycle. The system responds in 20ms to any changes in mains voltage.

This VRp system has a number of advantages:

- One magnetic component,
- Compact size and low weight,
- One PCB assembly,
- Few interconnections,
- Rapid response time,
- High efficiency,
- Low impedance,
- Power to load not interrupted during regulation, hence no di/dt,
- Automatic bypass allows critical load to receive power if electronics fail.

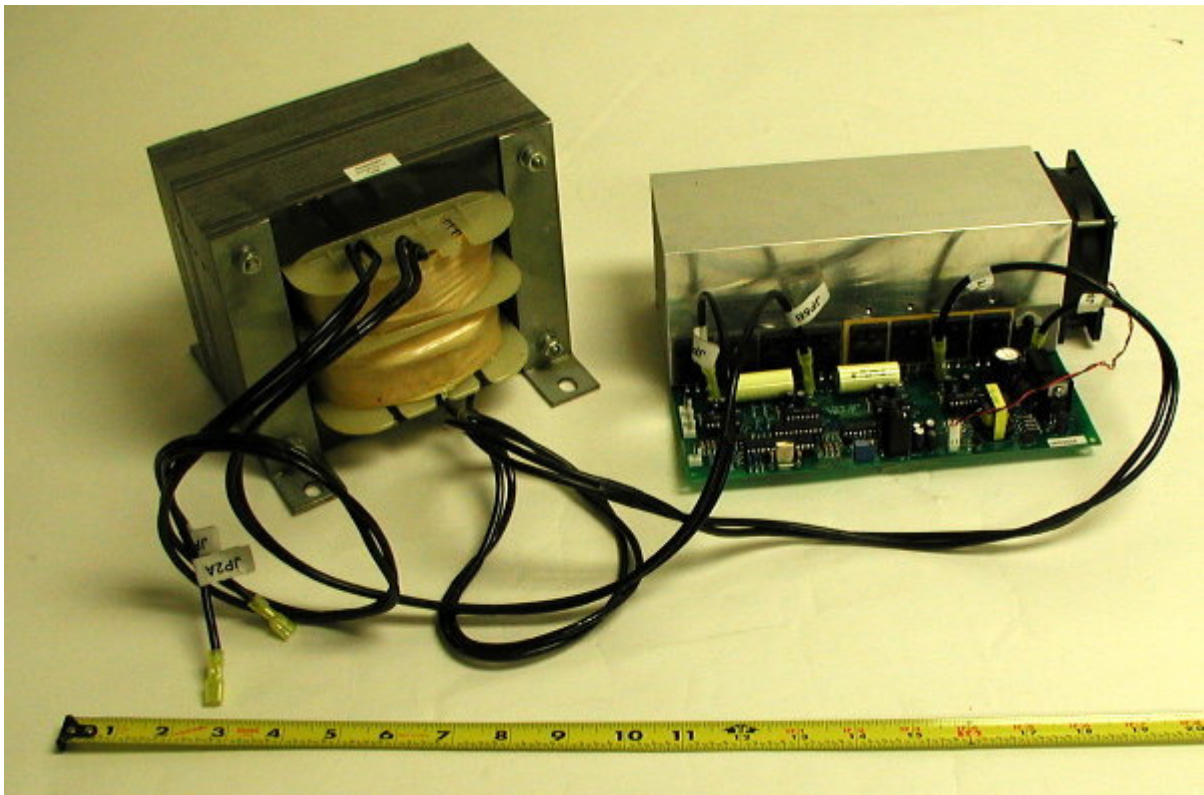

Figure 6 Picture of 7500VA single-phase system with buck-boost transformer and heatsink-pcb assembly

AVR Technology Comparison Table

Technology	Advantages	Drawbacks
Electromechanical	<ul style="list-style-type: none"> • Precise regulation • Low impedance • Excellent stability • High efficiency 	<ul style="list-style-type: none"> • Correction takes seconds • Voltage overshoots following mains cycling • Requires periodic replacement of brushes • Manual bypass only • Complex design
Electronic Tap-switching	<ul style="list-style-type: none"> • Low cost • High efficiency • Low impedance 	<ul style="list-style-type: none"> • Slow correction • Average reliability • Coarse regulation • Interrupts load current when switching • Complex internal wiring • Manual bypass only
Dual Conversion	<ul style="list-style-type: none"> • Precise regulation • Fast regulation • No switching of power path • Energy storage • Corrects frequency variations 	<ul style="list-style-type: none"> • Very High cost • Very Poor efficiency • Must be oversized for high-inrush loads • Complexity • Reliability
High-speed PWM VRp	<ul style="list-style-type: none"> • Precise regulation • Fast regulation • High efficiency • Low impedance • No switching of power path • Simple design • Automatic bypass • Reasonable cost 	<ul style="list-style-type: none"> • No energy storage • Does not correct frequency variation

Magnetics Selection

A major advantage of VRp topology is the fact that buck-boost transformer is not larger than a 2kVA isolation transformer for a system with output of 10kVA and with regulation of $\pm 20\%$. Conversely a similar transformer with a winding ratio of 10:1 would be able to handle 20kVA. The result is an economical approach as magnetic components are kept to a minimum.

Conventional transformers with CGO cores can be used at the lower power levels where losses due to harmonics from the inverter section are not high enough to impact efficiency. Of course, core materials such as thin-gauge, Hi-B materials that tolerate higher frequencies will improve efficiency by reducing AC losses due to eddy current and hysteresis of the material. Losses due to high-frequency skin-effect can be controlled by appropriate selection of copper conductor thickness; such as copper foil and litz wire.

Systems Efficiency

The typical VRp has an efficiency of 96%, but this can be improved by the selection of better magnetics and slower response time.

Conclusion

The VRp offers a reasonable improvement on the slow, electro-mechanical AVR, the electronic tap-switching AVR, and the dual-conversion AVR, as it offers many of the attractive features of these technologies at a reasonable price without trading off performance parameters. VRp does not cause di/dt problems, as it doesn't switch the power path, and it is highly efficient and attractively priced.

End footnotes

TSI Power Corporation, based in Wisconsin, USA, develops and manufactures electronic AVRs, DC-AC power inverters, and automatic transfer switches as well as customized equipment to suit specific needs. Customers include OEMs, telecoms, and governments.

Romarsh Ltd. is a major UK based manufacturer of transformers and inductors. It counts among its customers major blue-chip OEMs throughout the world. Romarsh manufactures TSi AVRs for sale in EMEA.

TSi/Romarsh have co-developed a range of AVRs suitable for countries with very poor mains stability.

About the authors

Peter Nystrom is the president of TSI Power Corporation and the developer of two generations of AVR products. Nystrom is the founder of three companies and has served as a consultant to a major telecommunications infrastructure manufacturer. He is a director of two UK companies and one US company. Peter can be contacted by email: peter.tsipower@gmail.com (TSi website: www.tsipower.com)

Paul Ling is the Technical Sales Director of Romarsh Ltd and is a committee member of the UK Magnetics Society. Paul can be contacted by email: paul@romarsh.co.uk (Romarsh website: www.romarsh.co.uk)